



TERMINATOR 2100PRO® OPERATION AND MAINTENANCE MANUAL



Read this Manual before you operate or service the equipment.

Carpet and Tile Removal Machinery
Innovatech Products & Equipment Co.
832 80th St SW Everett
WA 98203 USA Telephone
(425) 402-1881
1-800-267-6682
Fax (425) 402-8547
Email: sales@innovatechproducts.com

Copyright © 2008 Innovatech Products & Equipment Co. All Rights Reserved.

Document Number: 53-000030-01

Innovatech, Innovatech Products & Equipment Co., Terminator 2000, Terminator 2100XM, and Terminator 2100PRO are service marks of Innovatech Products & Equipment Co., in the United States and/or in other countries. All other brands, products, or service names are or may be trademarks or service marks of, and are used to identify, products or services of their respective owners.

Notice: The information in this document is provided "AS IS," without warranty of any kind, including, without limitation, any implied warranty of merchantability, non-infringement or fitness for a particular purpose. Disclosure of information in this material in no way grants a recipient any rights under Innovatech's patents, copyrights, trade secrets or other intellectual property rights. Innovatech reserves the right to make changes to this document at any time, without notice, and assumes no responsibility for its use.

The authors and Innovatech Products & Equipment Co., shall have no liability or responsibility to any person or entity with respect to any loss, cost, liability, or damages arising from the information contained in this document or any materials or the computer programs that accompany it.

Table of Contents

Declaration of Conformity	5
Introduction	6
About this Manual	6
Tools and Supplies	6
Warning Symbols.....	7
Safety Instructions	8
General Guidelines for Safe Operation	8
General Operating Instructions for the Terminator® 2100PRO	8
Safety Features	9
Safety Warnings	9
Ventilation Requirements.....	10
Guards, Warning Notices and Signs	11
Service Instructions and Personnel.....	11
Replacement Parts and Materials	11
Uncrating and Preparing the Terminator 2100PRO for Operation	12
Remove the Terminator 2100PRO from the Crate Using a Forklift.....	12
Remove the Terminator 2100PRO from the Crate Manually	12
Loading/Unloading Procedures	12
Controls and Machine Operation	14
Drive Controls	14
Ignition Switch, Indicators, and Blade Controls	15
Operating the T-2100PRO.....	15
Shutting Down the Terminator 2100PRO	16
Taking Up Floor Coverings.....	16
Blade Assembly	16
Ballast	17
Systems Inspection and Maintenance	19
Engine.....	19
Air Filter.....	19
Hood and Operator Seat.....	20
Maintenance	20
Safety Equipment Inspection and Maintenance	21
Fuel System.....	22
LPG Fuel Cylinder Replacement Procedure	22
Troubleshooting	22
Error Codes	23
Blade Selection Guide	25
Warranties	27

Innovatech Warranty.....	27
Recommended Safety Maintenance Procedures for LP Gas Fueled Equipment	28
Carbon Monoxide Warning	29
Carbon Monoxide – What Service Personnel Should Know!	29
Propane Safety	30
Precautions and Warnings	30
What to Do If You Smell Gas.....	30
OSHA FACT SHEETS.....	31
What Is Carbon Monoxide?	31
Are You Likely To Be Poisoned?	31
How Does Carbon Monoxide Harm You?	31
What Can You Do About Carbon Monoxide?	31
Suggestions to Prevent Carbon Monoxide Poisoning	32
What Are The Federal Standards?	32
Terminator 2100PRO Specifications	33
Terminator 2100PRO Parts Catalog	33
Console and Door Assembly	33
Engine and Pump Assembly	33
Hydraulic Assembly	33
Hydraulic Assembly Continued.....	33
10cc Pump and T-Case Fitting Assembly	33
Propane Tank Position with Hose	33
Lower Chassis and Weight Assembly	33
Wheel and Brake Assembly	33
Strobe Light Bracket and Hood Assembly.....	33

Declaration of Conformity

Manufacturer & Address:
Innovatech Products and Equipment
832 80th ST SW Everett, WA 98203

We declare under our sole responsibility that the product described as:

Machine description: Terminator 2100PRO ride on floor removal machine
Make: Terminator 2100PRO
Type: LPG Internal Combustion
Serial number:

Complies with the requirements of the following directives:

- Machinery Directives 98/37 (modified);
- Low Voltage Directive 73/23 (modified);
- Electromagnetic Compatibility Directive 89/336

Standards Considered:

EN 12100-1, EN12100-2, EN 60294-1

Date: April 2008 at: Innovatech

President

Gregory Dahl

Introduction

The Terminator® 2100PRO Carpet and Tile Removal Machine is intended for use on demolition projects, asbestos abatement projects, and smaller floor covering removal jobs. Designed and built by experienced floor covering demolition and installation experts, the machine incorporates several design features that are essential for efficient operation:

Tricycle wheelbase and short turning radius allows for better maneuvering and turning ability – especially in narrow spaces.

Blade vertical and tilt position adjustments allow for positioning the blade to the appropriate angle for the each application to improve efficiency.

Ballast in front and rear provides extra traction needed for tile and glue removal.

Built-in forklift transport slots allows for easy loading and unloading at job sites.

Propane powered engine provides high fuel efficiency and low air pollution. Propane does however produce carbon monoxide and other gases, which may be harmful to your health if not used in well-ventilated areas. See the Ventilation Requirements.

Catalytic Converter provides high fuel economy and lowers emission of harmful gasses.

If operated and cared for as instructed in this Manual, the Terminator 2100PRO provides trouble-free, safe, and efficient performance.

About this Manual

Read this Manual before you operate or service the equipment. This manual contains the information and procedures to assist you to operate and maintain the Terminator® 2100PRO safely and correctly. If you need additional information or assistance, please get in touch with our Customer Service Department:

Innovatech Products & Equipment Co.
832 80th St SW
Everett, WA 98203 USA
(425) 402-1881 or 800-267-6682
Fax (425) 402-8547
Email: sales@innovatechproducts.com

Tools and Supplies

The following tools and supplies are required for proper equipment maintenance and should be available at the job site.

- 1.) 4" or 7" Grinder
- 2.) WD 40
- 3.) 10"-15" Crescent Wrench
- 4.) ¾ Open End and Box Wrench
- 5.) 16-20 oz. Hammer
- 6.) Screw Driver Set
- 7.) Socket Set 1/4 – 3/4, 3/8 set or 1/2
- 8.) Safety Glasses
- 9.) Grease Gun
- 10.) Ear Plugs

Warning Symbols

Symbol	Explanation
	Read the Manual
	Safety Helmet
	Eye Protection
	Eye and Ear Protection
	Warning
	Sever Hazard

Safety Instructions

To ensure safe operation, only trained personnel should use the Terminator 2100PRO. To help ensure your safety as a designated operator, **read these safety instructions before you operate the equipment.**

The Terminator 2100PRO has unique features and systems. Read the following guidelines and instructions before operating or servicing the machine or equipment.

General Guidelines for Safe Operation

- Only qualified and trained personnel should operate the Terminator 2100PRO.
- **CAUTION:** The Terminator 2100PRO produces carbon monoxide while the engine is running. Provide adequate ventilation when operating the Terminator 2100PRO in an enclosed building.
- Only use the Terminator 2100PRO for the purpose for which it was designed. Attempting to alter the Terminator 2100PRO will invalidate applicable warranties and may endanger personnel and the machine.
- **DO NOT** use the Terminator 2100PRO on roofs or floors not designed to carry the weight of the machine. The Terminator 2100PRO weighs 2445lbs.
- Familiarize yourself with all safety features and controls before each use.
- Reduce speed when near personnel, walls, machinery, and other objects.
- Survey and inspect the work area for cracks, trenches, or objects that could catch or damage the blade of the machine.

General Operating Instructions for the Terminator[®] 2100PRO

- The Terminator 2100PRO is designed to remove carpet, tile, and glue residue from floors.
-  Position removed product so it rolls to the side of the machine or is removed by personnel.
WARNING: Never walk in front or behind the Terminator 2100PRO while it is running.
- Sharpen blades or dice material into narrower widths if machine slows down or seems to be struggling.
- Do not use the Terminator 2100PRO within one foot (12 inches) of walls or stationary objects. Striking walls or other objects with the Terminator 2100PRO may cause damage to the object, machine, or personnel.
- Use safe, OSHA approved tools and methods for sharpening blades.
- Make sure all safety equipment on the Terminator 2100PRO is installed and working properly; including a charged fire extinguisher and working back up beacon.
- Verify the work area has adequate ventilation before starting the engine on the Terminator 2100PRO.

Safety Features

The Terminator 2100PRO is equipped with several features to help ensure your safety and the safety of any personnel in the work area.

Warning Light and Back up Alarm: An amber light is installed on the top rear section of the hood. When the Terminator 2100PRO ignition is in the ON position, the warning light will flash. The back up alarm sounds when the drive control is set in **REVERSE** to provide a warning signal that the machine is moving in reverse.

Fire Extinguisher: A fire extinguisher is located on the hood behind the operator's seat. Regularly inspect the gauge and recharge the fire extinguisher as needed to maintain full capacity. Always recharge the extinguisher after each use.

Auto Stop: The Terminator 2100PRO has two drive levers located to the left and right of the operator's seat and a blade height switch located on the control lever. The drive levers control the forward, reverse, left, and right directions of the machine. The blade height switch raises and lowers the blade. You must push (forward) or pull (reverse) and hold the levers in position to drive the machine in the direction desired. When a lever is released, the Terminator 2100PRO automatically STOPS. The machine will not move again until you push/pull and hold the levers.

Operator Presence Switch and Safety Grips: The Terminator 2100PRO is equipped with an operator presence switch and trigger switches on the under side of the left and right grips. The operator must be seated on the operator seat and hold either of the safety switches to operate the machine. The wheel hydraulics will not function without an operator and one of the switches being held.

Warning: The Terminator 2100PRO will stop abruptly if both trigger switches are released or if the operator tries to leave the seat while the machine is moving.

CAUTION: Do not use the levers as a parking brake. Block wheels with a floor block when stopping on a ramp or incline. The machine will roll on any sloping surface without a floor block.

Safety Warnings

FAILURE TO FOLLOW THESE RULES MAY RESULT IN SERIOUS PERSONAL INJURY OR DEATH.

ALWAYS WEAR EYE PROTECTION. Wear eye protection to provide protection against flying particles from the front and side of the machine. All personnel in the work area, including the operator, must always wear eye protection when loading, operating, and servicing the machine.

ALWAYS WEAR EAR PROTECTION. Wear ear protection to protect the ears from exposure to high noise levels. All personnel in the work area, including the operator, must always wear ear protection when loading, operating, and servicing the machine.

ALWAYS WEAR A HARD HAT. Wear head protection to protect the head from flying debris. All personnel in the work area, including the operator, must always wear a hardhat when operating the machine.

ALWAYS PROVIDE PROPER VENTILATION. Ventilation is required when using the Terminator 2100PRO. Positive or negative pressure ventilators must be used in any enclosed space where the machine is to be used. Use Carbon Monoxide (CO) monitoring when the machine is used in doors. The Carbon Monoxide generated by propane engines can be hazardous to your health if proper ventilation is not provided.

Use caution while loading, operating, and running the Terminator 2100PRO.

- Do not operate the Terminator 2100PRO unless you have been provided instruction on the safe operation of the equipment.
- NEVER operate the Terminator 2100PRO unless every guard, warning notice, or sign is in place.
- DO NOT operate the Terminator 2100PRO while under the influence of drugs, alcohol, or medication.

- DO NOT operate the Terminator 2100PRO near an open flame or smoking materials.
- DO NOT run the machine onto piles of debris.
- NEVER operate the Terminator 2100PRO in any manner that may cause the machines to become unstable and tip over.
- NEVER engage in horseplay on or near the Terminator 2100PRO.
- ALWAYS use the seat belt on the Terminator 2100PRO. The seatbelt will help provide you the proper footing and balance.
- ALWAYS turn the off engine and turn the fuel flow control to OFF when the machine is not in use.
- NEVER stand directly behind or in front of the Terminator 2100PRO when the engine is running.
- NEVER put your hands or feet in the blade area when the engine is running.
- DO NOT exceed recommended speed.
- NEVER refuel, lift the hood, inspect the blade or otherwise service, or maintain the Terminator 2100PRO while the engine is running.
- DO NOT move the Terminator 2100PRO if the engine lid is open.
- NEVER sit or stand next to, under, or near the Terminator 2100PRO during transportation in a moving vehicle, whether by itself or with other equipment.
- NEVER attempt to use the Terminator 2100PRO on a non-horizontal surface.
- NEVER attempt to turn around, or otherwise maneuver, the Terminator 2100PRO on a ramp or hill.

Ventilation Requirements

- Use machine only in well-ventilated areas.
- ⚠ The internal combustion engine of the Terminator 2100PRO produces carbon monoxide gas. Carbon monoxide (CO) is a colorless, odorless, highly poisonous gas that is harmful and in sufficient concentrations may cause illness or death.
- When operating this machine indoors provide adequate ventilation to prevent the accumulation of Carbon Monoxide.
- When in doubt about ventilation stop operation until you are sure the ventilation is adequate. A Carbon Monoxide (CO) monitor is highly recommended to monitor the air whenever the Terminator 2100PRO is operated indoors.
- Read and understand the following OSHA Fact Sheet regarding Carbon Monoxide poisoning.

Guards, Warning Notices and Signs

The guards, warning notices, and signs are placed on the Terminator 2100PRO for your protection. Call the Customer Service Department to order a replacement if a guard, warning notice, or sign is damaged or lost.

Service Instructions and Personnel

The Terminator 2100PRO requires regular inspection and maintenance of the engine, the operating systems, and other parts. To prolong the safe and efficient operating life of the machine, clean and service it as instructed in the Maintenance section of this manual.

Always use trained personnel to service the equipment. If you need help with a service or maintenance problem, call our Customer Service Department.

Replacement Parts and Materials

The Terminator 2100PRO is designed and engineered to operate safely and efficiently with factory installed parts and materials. To ensure the continued safe and efficient operation of the equipment, use replacement parts and materials that meet both of the following requirements:

- Innovatech must authorize replacement parts and materials solely.
- Replacement parts and materials must be identical to the items originally provided with the machine, except as authorized by Innovatech.

Never use "equivalent" or substitute parts, except as expressly authorized by Innovatech.

If you fail to obey these restrictions, you may injure yourself, damage the Terminator 2100PRO, and invalidate applicable warranties.

If you are in doubt about any replacement parts or materials, call our Customer Service Department for assistance.

Uncrating and Preparing the Terminator 2100PRO for Operation

1. Inspect the outside of the Terminator 2100PRO crate completely upon delivery. Notify the carrier if the crate is damaged.
2. Carefully uncrate the machine and inspect it for damage that may have occurred during shipping. If the shipment is damaged, notify the carrier immediately.
3. Remove the crate debris, set aside the blades and other packages.
4. Follow the instruction to remove the Terminator 2100PRO from the crate.

Remove the Terminator 2100PRO from the Crate Using a Forklift

WARNING: Use the forklift slots to lift the Terminator 2100PRO.

Remove the Terminator 2100PRO from the Crate Manually

- 1.) Install a full propane tank.
- 2.) Remove the 2 x 4's from the edge of the crate and from between the wheels.
- 3.) At the rear of the machine, create a ramp using the 2 x 4's and crate material.
- 4.) Start the Terminator 2100PRO.
- 5.) Lift the front wheel off the crate by approximately five (5) inches. The jaw will be on crate.
WARNING: Keep feet from the area.
- 6.) Pull up on both control levers and move both levers back slowly. The machine will start moving slowly backwards.
- 7.) The jaw will roll back on the ramp. Both wheels must to come off evenly.
WARNING: Roll the machine straight back to prevent rolling.
- 8.) As the machine rolls back, make sure the center wheel clears the crate. Use the blade height switch to lift the wheel higher as needed.
- 9.) Once the machine is on the ramp, slide the machine all the way to the bottom.
- 10.) Lift the jaw and set the center wheel to the ground.

* ALWAYS turn OFF the engine when mounting or dismounting the Terminator 2100PRO.

Loading/Unloading Procedures

- Do not load or unload the Terminator 2100PRO on uneven ground. Make sure ramps are square to the ground.
- Always turn the engine OFF when transporting the Terminator 2100PRO by forklift or other vehicle.
- Load and unload the machine using a properly weighted forklift or lift-gate.
- Make sure all safety stops are installed when using a lift-gate.
- Never position personnel under or around the machine while moving it with other machinery.
- Park the machine with the blade completely down after loading.
- Properly secure the machine with chains, tire chocks, and other necessary tie downs.
- Never ride on or near the Terminator 2100PRO during transportation. It may tip, causing severe injury.

Inspect the lug nuts on the rear wheels; tighten the nuts to 70 inch-pounds torque.

Raise the hood.

DO NOT MOVE MACHINE WITH THE LID OPEN!

Using the respective dipstick, test the level of the engine oil and the hydraulic fluid. Add oil and hydraulic fluid as needed.

Inspect the fuel system connectors and valve. Make sure the valve is OFF.

Have two tanks of propane on hand: one to install and one in reserve. (Each tank provides approximately 3 to 4 hours operating time.)

CAUTION! Wear insulated gloves and handle the propane tanks and fuel with extreme care, according to the manufacturer's instruction.

DO NOT WORK WITH PROPANE NEAR A FLAME OR SPARKING EQUIPMENT.

Controls and Machine Operation

NOTE: Directional instructions (left, right, up, down, push, pull, etc.) are given from the operator's point of view.

Drive Controls



Figure 1 Operator Controls

The drive controls (two levers) are located to the right and left of the operator.

To move the machine forward, push the left and right levers forward at the same time and hold them in position.

To move the machine in reverse, pull back the left and right levers at the same time and hold them in position. The reverse alarm sounds.

To turn the machine to the left, push the right lever only.

To turn the machine to the right, push the left lever only.

AUTO STOP: When you release the drive levers, the engine continues to run but the machine stops moving.

Left Handle Thumb Controls

The throttle is control with the left thumb slider.

The upper thumb button operates the headlight.

The lower thumb button operates an optional water mister.

Right Handle Thumb Controls

The front blade is controlled with the right thumb slider.

Ignition Switch, Indicators, and Blade Controls

The operator controls and indicators consist of the ignition switch, headlight switch, throttle control, check engine light indicator, and information display.

The ignition switch is located to the left of the operator.

The check engine indicator LED is located near the ignition switch.

The tachometer is located to the right of the operator.

An informational display is located below the tachometer. The display provides the following information: Error Codes, Hour Meter, Throttle Position, Engine RPM, Battery Voltage, Coolant Temperature, Intake Air Temperature, and Oil Pressure. The error codes are described in the Error Codes section on page 23.

The blade control is located on the right thumb control. The switch controls the vertical position of the blade.

The throttle and headlight are operated using the thumb controls located on the left handle.

Operating the T-2100PRO

Use the following instructions as a general guide to operate the T-2100PRO. The operator will determine actual machine operation.

- 1.) Perform an inspection of the machine. Refer to Safety Equipment Inspection and Maintenance on page 21.
- 2.) Open the propane fuel valve, turning the valve counterclockwise. Check all the fuel lines for leaks that you can see, hear, or smell.

WARNING: If you detect a fuel leak, immediately close the fuel valve and contact service personnel.

- 3.) Tighten the line and test again.
- 4.) Sit on the machine and buckle the seat belt.
- 5.) Insert the key in the ignition switch and turn the key clockwise to start the engine.
- 6.) Slowly increase the throttle.
- 7.) Slowly push the right and left levers forward to move the machine very slowly.
- 8.) Continue to push the levers forward to increase speed.
- 9.) Slowly release the right and left levers to bring the machine to stop.
- 10.) If the machine drifts left, release the right lever a little and machine will straighten out. If the machine drifts to the right, release the left lever a little.
- 11.) Push the right lever and pull the left lever to turn the machine to the left.
- 12.) Push the left lever and pull the right lever to turn the machine to the right.

WARNING: Do not pull back or release either lever abruptly. This will cause the machine will turn very sharply.

WARNING: Do not put the blade into the jaw until familiar with the machine.

Shutting Down the Terminator 2100PRO



Note: The T-2100PRO is equipped with a LPG engine that may run on several seconds after the key is switched to the off position. This is a normal function of the engine control system running fuel out of the vapor hose to prevent engine backfiring on restart. The engine may run up to 5 seconds after the key is switched to off.

- 1.) Release the drive control levers.
- 2.) Lower the blade to the floor.
- 3.) Reduce the throttle to idle speed.
- 4.) Turn the ignition switch counter-clockwise to the OFF position.
- 5.) Turn the propane tank control off turning the valve clockwise.
- 6.) Inspect the machine for damage.
- 7.) For safety, remove the propane tank and key.

Taking Up Floor Coverings

- 1.) Insert the blade. (Refer to Blade Assembly below.)
- 2.) Lower the blade to the floor. As the blade flexes lift the caster wheel off the floor about ¼ inch.
- 3.) Drive the machine forward.
- 4.) As the Terminator 2100PRO is removing flooring material have another person at the side of the machine, remove all debris.

Blade Assembly

Blades are available in different configurations and thickness. An assortment of blades is included in the purchase price of the Terminator 2100PRO. Extra blades are available upon request from Innovatech Products & Equipment Co., Inc.

- 1.) Raise the blade assembly to the maximum up position, which is four inches off the floor.
- 2.) Unwrap the pre-sharpened blades and select the blade thickness and length you need for the job.
- 3.) Loosen the seven holding bolts.
- 4.) Insert the sharpened blade with the beveled side up.
- 5.) Tighten bolts firmly, starting from the center and working out. Bolts should be snug but not over tightened.

Ballast

The Terminator 2100PRO is equipped with 540 pounds of removable ballast. These ballast weights are located in front and rear to provide traction. Remove these weights to reduce traction and to transport the Terminator 2100PRO by forklift, truck, or elevator. Wear gloves when handling weights.

WARNING: Dropping or mishandling the ballast weights may cause personal injury or damage to the equipment.

Removing and Installing Front Ballast Weights



Caution: Remove one side of ballast at a time to avoid damage or injury.



Caution: Ballast weights are heavy. Use a lift or a two-person team when lifting the ballast weights.

Removal

1. Remove the two ½” bolts holding the ballast on.
2. Carefully remove the weights.

Installation

1. Make sure that the area of installation is clear of debris.
2. Carefully place the weights ensuring proper alignment of the bolt holes.
3. Install the ½” bolts in the holes on the ballast. Tighten the bolts.



Figure 2 Front Ballast

Removing and Installing Rear Ballast Weights

 **Caution:** Ballast weights are heavy. Use a lift or a two-person team when lifting the ballast weights.

 **Caution:** Use wood blocks, or a jack, brace the rear ballast weights to prevent them from dropping or falling.

Removal

1. Remove the ½" bolt holding the ballast.
2. Carefully remove the weights.

Installation

1. Make sure that the area of installation is clear of debris.
2. Carefully place the weights on the rear ballast bracket.
3. Install the ½" bolt in the hole on the ballast. Tighten the bolt.



Figure 3 Rear Ballast

Systems Inspection and Maintenance

Refer to the **PSI Operation and Maintenance Manual for the GM 1.6L L4 Engine** for complete maintenance instructions. When working on this machine always take into consideration the warnings about this machine and take extra care when evaluating the problem.

Engine

Before operating the T-2100Pro perform an inspection of the engine to verify all components are in place and in good condition. The propane-powered liquid-cooled engine is located under the hood.

- Check the air cleaner, making sure it is clean and in good condition.
- Check the engine oil using the dipstick. If the oil is low, remove the oil filler cap and add oil to the upper limit mark on the dipstick.

A safety guard covers the fan. **NEVER operate the machine unless the guard is in place. Always keep your hands away from the fan and all moving parts when the engine is running.**

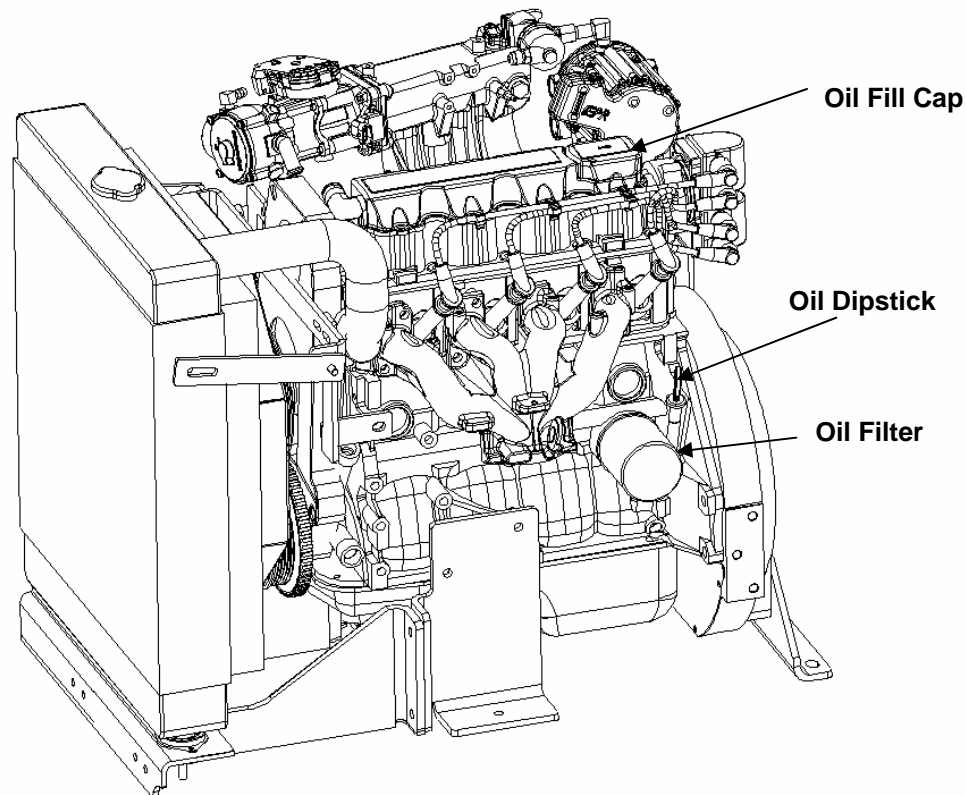

Figure 4 PSI 1.6L L4 Engine

Air Filter

The air filter helps prevent dust and dirt from entering the engine. Inspect the air filter before operating each day and replace when dirty.

Cooling System

Check the coolant level of the radiator daily and only when the engine is cool. The recommended time to do this is just prior to starting the engine for the first time each day. Maintain the coolant level at $\frac{3}{4}$ to $1\frac{1}{2}$ inches below the filler neck seat of the radiator when the coolant is cold. When ever coolant level checks are made, inspect the condition of the radiator cap rubber seal. Make sure it is clean and free of any dirt particles which would keep it from seating on the filler neck seat. Rinse off with clean water if necessary.



WARNING: Never remove the radiator cap under any conditions while the engine is operating. Wait until the engine has cooled, then wrap a thick cloth around the radiator cap, and turn slowly to the first stop. Step back while the pressure is released from the cooling system. When all the pressure has been released, press down on the cap and remove it slowly.



Note: DO NOT add coolant to any engine that has become overheated until the engine cools. Adding coolant to an extremely hot engine can result in a cracked block or cylinder head.

The engine manufacturer recommends the cooling system be filled with a 50/50 mixture of antifreeze and water. The use of DexCool "Long Life" type coolant (orange) is required.

Hood and Operator Seat

The hood covers the engine, fan, fuel supply and their related systems. The top of the hood contains the fire extinguisher, amber back up light, and the propane tank.

Radiator

Inspect the exterior of the radiator for obstructions. Remove all bugs, dirt, or foreign material. Use care to avoid damaging the core fins. If available, use low-pressure compressed air or a stream of water in the opposite direction of the normal airflow. Check all hoses and connections for leaks. If any of the hoses are cracked, frayed, or feel spongy, they must be replaced.

Fan Belts

The water pump is usually belt driven. The same belt may also drive the fan and/or the alternator. The drive belts should be properly adjusted at all times.

Maintenance

- 1) Grease the caster wheel at three fittings every 30 hours. There are three fittings, two on the wheel and one on the housing.
- 2) Remove debris caught between the wheel and the housing. Clean out wheel and housing regularly.
- 3) Change the engine oil every 3 months or 200 hours with SAE 10W-30. Check the engine owner's manual for oil recommendations for temperatures below 32° F.
- 4) Change the oil filter with AC Delco model: 94632619 – (available from Innovatech).
- 5) Check hydraulic oil once a week. Change every 18 months with NUTO H 46 or ISO 46 or if fluid is overheated 160°F – 180°F or higher, filter every 60 hours.
- 6) Clean the caster wheel and rear tires using a wire wheel as necessary.
- 7) Change the air cleaner when dirty (available from Innovatech).
- 8) Change spark plugs every 12 months or 200 hours.
- 9) Inspect the machine for leaks, find and tighten fittings – do not over tighten fittings.

10) Check all hoses and clamps once a week.

11) Inspect rear tires and lug bolts. Tighten lug bolts as needed to 70-foot pounds torque.

12) Check wheel hub every 60 hours of operation. Wheel hub should be tightened from 310 to 350-foot pounds (ft.-lbs).

Safety Equipment Inspection and Maintenance

Verify that the following equipment is proper working condition before operating the T-2100PRO.

- Fire extinguisher
- Backup light and siren
- Parking brake

Fuel System

The fuel system consists of propane tank, fuel lines, connectors, and flow control. The Terminator 2100PRO is designed to accommodate a three-gallon tank, which will usually provide about three to four hours running time. Keep a reserve tank on hand.

LPG Fuel Cylinder Replacement Procedure

WARNING: NO SMOKING – Do not replace fuel cylinders in areas that have a source of fuel ignition.

- 1.) Close the cylinder valve and run engine until it stops prior to disconnecting the fuel hose from the tank.
- 2.) Remove the strap holding the propane tank.
- 3.) Remove the empty tank and replace with a full tank.
- 4.) Reconnect the strap and make sure it is locked in position.
- 5.) Connect the fuel hose.
- 6.) Open the valve slowly so the hose and tank pressure can equalize or the valve may slug. Should leakage occur, close valve and have qualified personnel make repairs.

NOTE: THE ABOVE IS PROVIDED AS A GUIDE. FOR ADDITIONAL INFORMATION, CONSULT THE NATIONAL FIRE PROTECTION ASSOCIATION PAMPHLET 58 FOR THE SAFE STORAGE AND HANDLING OF LIQUEFIED PETROLEUM GASES.

Troubleshooting

Condition	Probable Cause	Corrective Action
Engine will not crank or is cranking slowly	Discharged Battery	Charge or Replace Battery
	Loose Battery cables	Clean and Reconnect.
	Ignition Switch Failure	Replace or Repair Ignition Switch
	Starter Failure	Replace or Repair Starter
	Charging System	Test; Replace or Repair
	Wiring	Inspect and Repair
Engine cranks but will not start	No Fuel In Propane Cylinder	Check and Fill
	Propane Cylinder Valve Turned Off	Check the propane tank couple. Turn On Valve
	No Spark	Check Coil, Ignition Switch and spark plug wires. Check all fuses under the control panel.
Engine hesitation or Improper idle	Dirty Throttle Body	Clean
	Improper Tightening of Manifold	Tighten Manifold Bolts
Excessive fuel consumption	Worn Parts	Service Tune-Up
Engine Runs but the machine will not move		Customer Service Department for assistance

Error Codes

The Terminator 2100PRO is equipped with an informative display. In addition to real time engine statistics (RPM, voltage, oil pressure, and temperature), the information display also provides diagnostic error codes.

DTC Code	SPN/FMI Code	Issue
16	636:8	Crank never synced at engine start
91	94:4	Fuel pressure sensor voltage low
92	94:3	Fuel pressure sensor voltage high
107	106:4	MAP low voltage
108	106:16	BP High pressure
111	105:15	IAT higher than expected
112	105:4	IAT low voltage
113	105:3	IAT high voltage
116	110:15	ECT higher than expected
117	110:10	ECT low voltage
118	110:3	ECT high voltage
121	51:1	TPS 1 lower than TPS 2
122	51:4	TPS 1 signal low voltage
123	51:3	TPS 1 signal high voltage
127	105:0	IAT higher than expected 2
129	108:1	BP low pressure
134	724:10	EGO 1 Open/Inactive
154	520208:10	EGO 2 Open/Inactive
171	520200:0	Adaptive learn high gasoline
172	520200:1	Adaptive learn low gasoline
182	174:4	Gasoline temperature sensor low voltage
183	174:3	Gasoline temperature sensor high voltage
187	520240:4	LPG fuel temperature low voltage
188	520240:3	LPG fuel temperature high voltage
217	110:0	ECT higher than expected 2
219	515:15	Max govern speed override
221	51:0	TPS 1 higher than expected 2
222	520251:4	TPS 2 signal low voltage
223	520251:3	TPS 2 signal high voltage
336	636:2	Crank sync noise
337	636:4	Crank loss
420	520211:10	Gasoline catalyst monitor
524	100:1	Oil pressure low
562	168:17	System voltage low

563	168:15	System voltage high
601	628:13	Flash checksum invalid
604	630:12	RAM failure
606	629:31	COP failure
642	1079:4	External 5V reference low
643	1079:3	External 5V reference high
685	1485:5	Power relay open
686	1485:4	Power relay shorted
687	1485:3	Power relay short to power
1111	515:16	Fuel rev limit
1112	515:0	Spark rev limit
1151	520206:0	Closed loop multiplier high LPG
1152	520206:1	Closed loop multiplier low LPG
1155	520204:0	Closed loop multiplier high gasoline
1156	520204:1	Closed loop multiplier low gasoline
1161	520202:0	Adaptive learn high LPG
1162	520202:1	Adaptive learn low LPG
1165	520213:10	LPG catalyst monitor
1171	520260:0	LPG pressure higher than expected
1172	520260:1	LPG pressure lower than expected
1173	520260:31	EPR comm lost
1174	520260:3	EPR voltage supply high
1175	520260:4	EPR voltage supply low
1176	520260:12	EPR internal actuator fault
1177	520260:12	EPR internal circuitry fault
1178	520260:12	EPR internal comm fault
1612	629:31	RTI 1 loss
1613	629:31	RTI 2 loss
1614	629:31	RTI 3 loss
1615	629:31	A/D loss
1616	629:31	Invalid interrupt
1626	639:12	CAN Tx failure
1627	639:12	CAN Rx failure
1628	639:13	CAN Address conflict failure
2111	51:7	Unable to reach lower TPS
2112	51:7	Unable to reach higher TPS
2229	108:0	BP High Pressure

Blade Selection Guide

Part Number	Blade Description	Best for Removing Material Types
Universal Blades, Sharpened Blades		
81-0051	4x9x.074	VCT/VAT/Glue Scraping/Vinyl
81-0054	4x9x.092	VCT/VAT/Glue Scraping/Vinyl
81-0057	4x13x.074	VCT/VAT/Glue Scraping/Vinyl
81-0060	4x13x.092	VCT/VAT/Glue Scraping/Vinyl
81-0063	4x18x.074	VCT/VAT/Glue Scraping/Vinyl
81-0066	4x18x.092	VCT/VAT/Glue Scraping/Vinyl
81-0069	4x26x.074	VCT/VAT/Glue Scraping/Vinyl
81-0072	4x26x.092	VCT/VAT/Glue Scraping/Vinyl
81-0075	4x24x.074	VCT/VAT/Glue Scraping/Vinyl
Self Dicing Blades, Sharpened Blades, Notched, Self Dicing		
81-0053	4x9x.074	Carpet-Sheet Vinyl
81-0056	4x9x.092	Carpet-Sheet Vinyl
81-0059	4x13x.074	Carpet-Sheet Vinyl
81-0062	4x13x.092	Carpet-Sheet Vinyl
81-0065	4x18x.074	Carpet-Sheet Vinyl
81-0068	4x18x.092	Carpet-Sheet Vinyl
81-0071	4x26x.074	Carpet-Sheet Vinyl
81-0074	4x26x.092	Carpet-Sheet Vinyl
Sharpened Blades With Notches		
81-0052	4x9x.074	VCT/VAT
81-0055	4x9x.092	VCT/VAT
81-0058	4x13x.074	VCT/VAT
81-0061	4x13x.092	VCT/VAT
81-0067	4x18x.092	VCT/VAT
81-0070	4x26x.074	VCT/VAT/Mastic Re-Scrape
81-0073	4x26x.092	VCT/Carpet on Rough Floors
Removal Teeth, Ceramic Tile & Hardwood Teeth		
83-0001	4x9x.074 Milled	Ceramic Tile/Hardwood
83-0002	4x9x.092 Cast	Ceramic Tile/Hardwood
Blades		
81-0050	3x8x.062 Sharpened	Paper/Mastic/Thin Coating
81-0045	3x13x.062 Sharpened	Mastic/Thin Coating-Elastomeric
81-0047	3x26x.062 Sharpened	Paper/Mastic/Thin Coating
81-0082	4.5x10x.125 Sharpened	Parquet/Wood/Mortar

81-0083	4.5x10x.125 Sharp/w-notch	Self-Leveling/Mortar/2-Layer Tile
81-0084	4.5x13x.125 Sharpened	Parquet/Wood/Mortar/2-Layer Tile
81-0086	4.5x26x.125 Sharpened	Parquet/Wood/Mortar/2-Layer Tile
81-0088	9x26x.125 Sharp/w-notch	Plywood/4-Layer Tile/Planks

NOTE: Blade selection depends entirely upon the material to be removed and the type of adhesive used to adhere the floor covering or coating to the concrete. Smaller blades are more effective in removing tough material or adhesive.

Notched self-dicing (SD) blades can be used to ditch (skip rows) the material or using only one side (not skipping rows). If a blade smaller than 9 inches is required to successfully remove material, it is suggested that a 9 or 13 inch blade be cut down, leaving the blade a full 9 or 13 inches where it will be clamped into the jaw.

Warranties

Innovatech Warranty

Innovatech warrants to the original buyer for a period of one (1) year from the date of delivery or 300 operating hours (whichever comes first), that Equipment is free from defects in materials and workmanship and that the Equipment conforms to the operating specifications supplied with the Equipment. The foregoing warranty is subject to proper operation and maintenance of the Equipment in accordance with the operating instruction and manual supplied to Buyer with the Equipment.

Buyer shall make warranty claims in writing. Innovatech's sole obligation under the foregoing warranty, where it appears to Innovatech's satisfaction that the defect was present at the time of delivery, is at Innovatech's sole option, to repair, replace, or correct any such defect.

EXCEPT AS STATED ABOVE THERE ARE NO WARRANTIES, EXPRESS OR IMPLIED. INNOVATECH EXPRESSLY DISCLAIMS ANY WARRANTY, EXPRESS OR IMPLIED, THAT THE EQUIPMENT IS OF MERCHANTABLE QUALITY, OR THAT IT CAN BE USED FOR, OR IS FIT FOR ANY PARTICULAR PURPOSE. ANY DESCRIPTION OF THE EQUIPMENT IN MANUALS, BROCHURES, OR LITERATURE AND ANY USE OF ANY SAMPLE, MODEL, OR PROTOTYPE OF THE EQUIPMENT IS FOR THE SOLE PURPOSE OF IDENTIFYING OR ILLUSTRATING THE EQUIPMENT, IS NOT PART OF THE BASIS OF THE AGREEMENT BETWEEN INNOVATECH AND BUYER, AND DOES NOT CONSTITUTE A WARRANTY THAT THE EQUIPMENT, AS SUPPLIED, WILL CONFORM TO ANY DESCRIPTION OR TO ANY SAMPLE, MODEL OR PROTOTYPE. INNOVATECH DISCLAIMS ANY WARRANTY RESPECTING OPERATING CAPACITY OR CAPABILITY OF THE EQUIPMENT OR THE ABILITY OF THE EQUIPMENT TO MEET ANY PARTICULAR NEED OR REQUIREMENT OF THE BUYER. THE EQUIPMENT IS POWERED TO OPERATE AS STATED IN THE OPERATING SPECIFICATIONS SUPPLIED WITH THE EQUIPMENT BUT IT IS UNDERSTOOD AND AGREED TO BY BUYER THAT ACTUAL OPERATING CAPABILITIES VARY UNDER DIFFERENT OPERATING CONDITIONS FOR WHICH INNOVATECH CAN ASSUME NO RESPONSIBILITY.

BUYER'S EXCLUSIVE REMEDY FOR CLAIMS ARISING UNDER THIS WARRANTY SHALL BE FOR REPAIR OR, AT INNOVATECH'S SOLE OPTION, REPLACEMENT OF ANY ITEM OF DEFECTIVE EQUIPMENT. INNOVATECH'S LIABILITY FOR ANY LOSSES OR DAMAGE, WHETHER ON ACCOUNT OF NEGLIGENCE, BREACH, WARRANTY OR OTHERWISE SHALL IN NO EVENT EXCEED THE PURCHASE PRICE OF THE PARTICULAR ITEM OF EQUIPMENT WITH RESPECT TO WHICH SUCH LOSSES OR DAMAGE OCCURRED. IN NO EVENT WILL INNOVATECH BE LIABLE FOR ANY DAMAGES CAUSED BY BUYER'S FAILURE TO PERFORM BUYER'S RESPONSIBILITIES, OR FOR ANY LOST PROFITS, LOST PRODUCTION, LOSS OF ANTICIPATED PROFITS OF OTHER INCIDENTAL OR CONSEQUENTIAL DAMAGES, EVEN IF INNOVATECH HAS BEEN ADVISED OF THE POSSIBILITY OF SUCH DAMAGES. IN NO EVENT WILL INNOVATECH BE LIABLE FOR ANY DAMAGES RESULTING FROM ANY CLAIM AGAINST BUYER BY ANY OTHER PARTY.

FACTORY SERVICE

A warranty will not be valid unless a written claim authorization comes with returned parts. Innovatech will not provide for any shipping costs for items returned for repair. To obtain warranty repairs, buyer must prepay shipment and return all warranty parts to Innovatech. Damage occurring during shipment is deemed the responsibility of the carrier and claims should be made directly with the carrier.

If equipment is sent to Innovatech for repair, it is the customer's responsibility to pay for any non-warranty replacement parts and the current hourly labor rates for any work done on any machine or part. Service is available upon request; call Innovatech for current labor rates.

Recommended Safety Maintenance Procedures for LP Gas Fueled Equipment

WARNING: LP GAS is a combustible fuel that is heavier than air. Escaping gas may accumulate in low areas. The fuel cylinder should be mounted so that it does not extend outside the truck.

Turn off the fuel valve when the machine is not in service.

Use only Underwriters Laboratories or Factory Mutual listed LP-GAS hose assemblies where pressure fuel lines are required.

Install all threaded pipe fittings using an approved sealing compound.

Support fuel lines with clamps to minimize chafing and wear.

The LP-GAS solenoid valve should be wired to an automatic shut off switch (oil pressure or vacuum) to prevent leakage of gas in the event the ignition is on without the engine running.

Check the propane solenoid or vacuum shutoff valve for leakage as follows:

- 1) Turn fuel cylinder valve off, start and run engine until it stops.
- 2) Install a 0 to 30 PSI pressure gauge per instruction A or B.
 - a. Primary test of single units consisting of primary and secondary regulators.
 - b. Between the primary and secondary stage regulators when the propane system consists of two separate regulators.
- 3) Open cylinder fuel valve. The pressure gauge should maintain a zero reading. If it does not, replace or repair the solenoid valve or vacuum shut off valve.

An odor is added to LP-GAS to help detect leaks. If the gas odor is detected the fuel cylinder supply valve and engine should be turned off. Remove all sources of ignition, and ventilate the area. Make all of the necessary repairs before you turn the fuel supply on.

The complete LP-GAS system should be inspected periodically. Check all hoses for wear, connections for leaks and all parts for damage.

NOTE: Fuel hoses have a limited life expectancy. They should be checked for cracking and drying due to age. Hoses with visible signs of age should be replaced. Use only Underwriters Laboratories or Factory Mutual listed LP-GAS parts for replacements.

NOTE: The above information is provided as a guide. Consult the National Fire Protection Association pamphlet 58 for the safe storage and handling of liquefied petroleum gases.

Governmental safety regulations in your locality could vary. Check with the authority having jurisdiction to be sure that you meet all of their requirements. Contact the manufacturer for detailed service information.

SERVICE WORK SHOULD BE PERFORMED BY QUALIFIED PERSONNEL ONLY

Carbon Monoxide Warning

IMPORTANT!

Carbon Monoxide – What Service Personnel Should Know!

OSHA Requirement

The CO level shall not exceed 35 ppm measured over an 8-hour period in the work environment.

How does parts per million (ppm) relate to percentage numbers?

One million parts per million equals one hundred percent of the engines exhaust gases.

- 10% CO EQUALS 100,000 PPM
- 1% CO EQUALS 10,000 PPM
- .1% CO EQUALS 1,000 PPM
- .01% CO EQUALS 100 PPM

For each one one-hundredth of one percent, you will have 100 ppm.

Example: $.01\% \times 1,000,000 \text{ ppm CO} = 100 \text{ ppm CO}$.

With adequate ventilation and following the enclosed adjustment instructions, you should be able to keep the carbon monoxide level below the OSHA requirement.

We strongly recommend the use of a carbon monoxide analyzer.

Propane Safety

Liquid petroleum gas (propane) is flammable and potentially explosive. ALWAYS obey proper handling, lighting, and ventilating procedures provided by the manufacturer. In addition, obey the safety warnings and procedures below, which are provided to supplement, not replace, or substitute for the manufacturer's instructions.

NOTE: All new propane tanks must be purged before use.

Precautions and Warnings

Wear insulated gloves when you handle propane tanks.

Do not attempt to adjust the pressure regulator because the manufacturer sets it. Only a qualified liquid petroleum gas service technician should make any required adjustments.

Inspect the fuel lines and connectors before each job or at the beginning of the day, to detect any leaks or potential problems. NEVER check for propane leaks with an open flame.

NEVER use ammoniated household-type detergents to detect leaks or to clean any portion of the fuel system or the tank. These substances can cause cracks on brass fittings and on the fuel line. If the leak cannot be located, take the tank to a certified liquid petroleum gas service representative.

NEVER store or carry propane containers in a closed space or inside your passenger vehicle. Propane containers are equipped with safety devices that relieve excessive pressure by discharging gas to the atmosphere and leaks can occur at the fittings or connectors.

NEVER fill a tank more than 80% of capacity. Overfilling can cause uncontrolled gas flow, which in turn, can cause fire and/or explosion.

What to Do If You Smell Gas

- 1.) Immediately extinguish any open flames, pilot lights and all smoking materials.
- 2.) Turn the engine OFF; do not touch any electrical switches or other device that may produce sparks.
- 3.) Shut OFF the fuel flow switch.
- 4.) Open all doors and windows to allow maximum ventilation.
- 5.) Leave the area until the odor clears.
- 6.) Inspect the fuel lines and connectors to determine the source of the leak. Correct the problem before you use the Terminator 2100PRO again.

OSHA FACT SHEETS

CARBON MONOXIDE POISONING

U.S. Department of Labor

Program Highlights

Fact Sheet No. OSHA 92-11

What Is Carbon Monoxide?

Carbon monoxide -- a colorless, odorless, tasteless gas -- is one of the most common industrial hazards. Mild poisoning can cause such symptoms as nausea, dizziness, or headaches while severe poisoning can result in brain or heart damage or even death. The incomplete burning of any material containing carbon, such as gasoline, natural gas, oil, propane coal, or wood, produces this poisonous gas. Forges, blast furnaces and coke ovens all produce carbon monoxide, but one of the most common sources of exposure in the workplace is the internal combustion engine.

Be suspicious of carbon monoxide poisoning if you develop headache, flushed face, dizziness, or weakness. Bear in mind that although carbon monoxide has no telltale odor, it may mix with gases that do have an odor. Thus, the smell of other gases does not mean the absence of carbon monoxide.

Are You Likely To Be Poisoned?

If you have a heart condition, your condition may be aggravated by carbon monoxide. Ingestion of barbiturates and alcohol may increase the gas health effects. Further, smokers will have a higher carboxyhemoglobin than nonsmokers have, and therefore face higher risk from carbon monoxide exposures on the job.

Harmful levels of carbon monoxide are a potential danger to: acetylene workers, blast furnace workers, boiler room workers, brewery workers, carbon black makers, coke oven workers, customs workers, diesel engine operators, dock workers, garage mechanics, metal oxide reducers, miners, organic chemical synthesizers, petroleum refinery workers, pulp and paper workers, steel workers, toll booth and tunnel attendants, and warehouse workers.

How Does Carbon Monoxide Harm You?

Large amounts of carbon monoxide can kill in minutes. The more carbon monoxide in the air and the longer you are exposed to it, the greater the danger. Any one or more of the following symptoms can signal carbon monoxide poisoning: headaches, tightness across the chest, nausea, drowsiness, inattention, or fatigue. As the amount of carbon monoxide in the air increases, symptoms that are more serious may develop such as lack of coordination, weakness, and confusion.

The poisoning can be reversed if caught in time. However, even if you recover, acute poisoning may result in permanent damage to the parts of your body that require a lot of oxygen, such as the heart and brain. There is a significant reproductive risk involved with carbon monoxide. An American Journal of Industrial Medicine article quotes two studies showing that acute carbon monoxide exposures that were non-lethal to the mother were associated with fetal loss.

What Can You Do About Carbon Monoxide?

If you suspect carbon monoxide, get out of the area and into the open fresh air. Remove anyone overcome by the gas immediately and give the person artificial respiration. Call for a doctor and continue the artificial respiration until the doctor arrives or the person recovers. Prompt action can make the difference between life and death.

Suggestions to Prevent Carbon Monoxide Poisoning

Employers

- 1.) Install an effective ventilation system to remove poisonous carbon monoxide from the area.
- 2.) Maintain appliances and equipment in good order, adjusting flames, burners, and drafts to reduce the formation of carbon monoxide.
- 3.) Consider switching from fossil fuel-powered equipment to battery-powered machinery when possible.
- 4.) Provide approved respirators for emergency use. Regular respirators (negative pressure) will not work in this atmosphere. If necessary, provide an independent air supply to workers.
- 5.) Install carbon monoxide monitors or regularly test air in areas when carbon monoxide is generated or used.
- 6.) Provide pre-placement and periodic medical examinations for workers who may be exposed to carbon monoxide. If possible, transfer affected workers to other jobs.
- 7.) Instruct workers in the hazards of carbon monoxide and train them in the proper use of respirators.

Workers

- 1.) Report to your employer any condition that might make carbon monoxide form or accumulate.
- 2.) Be alert to ventilation problems, especially in enclosed areas where gases of burning fuels may be released.
- 3.) Report complaints early. Do not overexert yourself if you suspect carbon monoxide poisoning. Physical activity increases the body's need for oxygen and thus increases the danger of poisoning.
- 4.) In you get sick, do not forget to tell you doctor about the possibility of exposure to carbon monoxide.
- 5.) Think carefully about your smoking habits. Tobacco, when burned, releases carbon monoxide, which reduces the oxygen-carrying ability of the blood, even before any industrial exposure is added.

What Are The Federal Standards?

The Occupational Safety and Health Administration (OSHA) standard for exposure to carbon monoxide prohibits workers' exposure to more than 35 parts of the gas per million parts of air (ppm), averaged over an 8-hour workday. There is also a ceiling limit of 200 ppm (as measured over a 15-minute period.)

* This is one of a series of fact sheets highlighting U.S. Department of Labor programs. It is intended as a general description only and does not carry the force of legal opinion.

Terminator 2100PRO Specifications

Dimension	Units
Width	27in (.69m)
Height	62in (1.58m)
Length	62in (1.58m)
Length with jaw removed	49in (1.245)
Weight	Units
Empty Weight	1905 lbs (864kg)
Removable Weight	540 lbs (254kg)
Maximum Weight	3295lbs (1494kg)
Standard Weight	2445lbs (1109kg) (3 front, 3 rear, 2 wheel weights and jaw)
Front Jaw down pressure	550lbs (250kg) (13" jaw with blade)
Caster wheel down pressure	945lbs (429kg)
Rear Wheel down pressure	1500lbs (680kg) (750lbs/tire)
Engine	Units
Engine Type and Model	GM 1.6L L4
Horse Power	65 HP @ 3,600rpm
Torque	90.0lb-ft @ 2,800rpm
Maximum RPM +/- 150rpm	3,000rpm
Fuel and Oil	Units
Fuel Type	LPG (Propane content of 95% or higher)
Engine oil type	SAE 30, API SJ
Engine oil capacity	3.7qts. with Filter (3.5L)
Hydraulic Oil	Units
Hydraulic oil type	60SUS (10cSt)
Hydraulic oil temperature rating	Continuous: 195°F (90° C), Interim: 212°F (100° C), Peak: 230 F (110 C),
Hydraulic oil capacity	15 US gallons (11.35L)
Coolant Capacity	10qts. with radiator